

Features

- 100V,15A
- $R_{DS(ON)} = 95m\Omega$ (Typ.) @ $V_{GS} = 10V$
- $R_{DS(ON)} = 100m\Omega$ (Typ.) @ $V_{GS} = 4.5V$
- Low Total Gate Charge
- Low Reverse Transfer Capacitance
- Improved dv/dt Capability
- Fast Switching Speed

Product Summary



V_{DS}	100	V
$R_{DS(ON),TYP@ V_{GS}=10 V}$	95	m Ω
I_D	15	A

Application

- Uninterruptible Power Supply(UPS)
- Inverter System

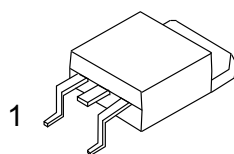

TO-252

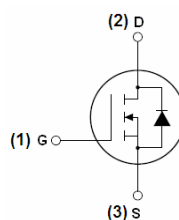

N-channel

Absolute Maximum Ratings ($T_C=25^\circ C$ unless otherwise specified)

Symbol	Parameter	Max.	Units	
V_{DSS}	Drain-Source Voltage	100	V	
V_{GSS}	Gate-Source Voltage	± 20	V	
I_D	Continuous Drain Current	$T_C = 25^\circ C$	15	A
		$T_C = 100^\circ C$	10	A
I_{DM}	Pulsed Drain Current ^{note1}	60	A	
P_D	Power Dissipation	$T_C = 25^\circ C$	55	W
$R_{\theta JC}$	Thermal Resistance, Junction to Case	2.72	$^\circ C/W$	
T_J, T_{STG}	Operating and Storage Temperature Range	-55 to +175	$^\circ C$	

Electrical Characteristics ($T_C=25^{\circ}\text{C}$ unless otherwise specified)

Symbol	Parameter	Test Condition	Min.	Typ.	Max.	Units
Off Characteristic						
$V_{(BR)DSS}$	Drain-Source Breakdown Voltage	$V_{GS}=0V, I_D=250\mu A$	100	-	-	V
I_{DSS}	Zero Gate Voltage Drain Current	$V_{DS}=100V, V_{GS}=0V, T_J=25^{\circ}\text{C}$	-	-	1.0	μA
I_{GSS}	Gate to Body Leakage Current	$V_{DS}=0V, V_{GS}=\pm 20V$	-	-	± 100	nA
On Characteristics						
$V_{GS(th)}$	Gate Threshold Voltage	$V_{DS}=V_{GS}, I_D=250\mu A$	1.0	1.6	3.0	V
$R_{DS(on)}$	Static Drain-Source on-Resistance <small>note2</small>	$V_{GS}=10V, I_D=10A$	-	95	110	m Ω
		$V_{GS}=4.5V, I_D=5A$	-	100	130	m Ω
g_{FS}	Forward Transconductance	$V_{GS}=5V, I_D=4A$	2	-	-	S
Dynamic Characteristics						
C_{iss}	Input Capacitance	$V_{DS}=50V, V_{GS}=0V, f=1.0\text{MHz}$	-	932	-	pF
C_{oss}	Output Capacitance		-	37	-	pF
C_{rss}	Reverse Transfer Capacitance		-	21	-	pF
Q_g	Total Gate Charge	$V_{DS}=80V, I_D=10A$	-	19.2	-	nC
Q_{gs}	Gate-Source Charge		-	3.4	-	nC
Q_{gd}	Gate-Drain("Miller") Charge		-	6.1	-	nC
Switching Characteristics						
$t_{d(on)}$	Turn-on Delay Time	$V_{GS}=10V, V_{DD}=50V, R_L=2.8\Omega, R_{REN}=6\Omega, I_D=10A$	-	12.6	-	ns
t_r	Turn-on Rise Time		-	6	-	ns
$t_{d(off)}$	Turn-off Delay Time		-	32.5	-	ns
t_f	Turn-off Fall Time		-	4.3	-	ns
Drain-Source Diode Characteristics and Maximum Ratings						
I_S	Maximum Continuous Drain to Source Diode Forward Current		-	-	15	A
I_{SM}	Maximum Pulsed Drain to Source Diode Forward Current		-	-	60	A
V_{SD}	Drain to Source Diode Forward Voltage	$V_{GS}=0V, I_S=10A$	-	-	1.2	V

Notes: 1. Repetitive Rating: Pulse Width Limited by Maximum Junction Temperature

 2. Pulse Test: Pulse Width $\leq 300\mu s$, Duty Cycle $\leq 2\%$

Typical Performance Characteristics

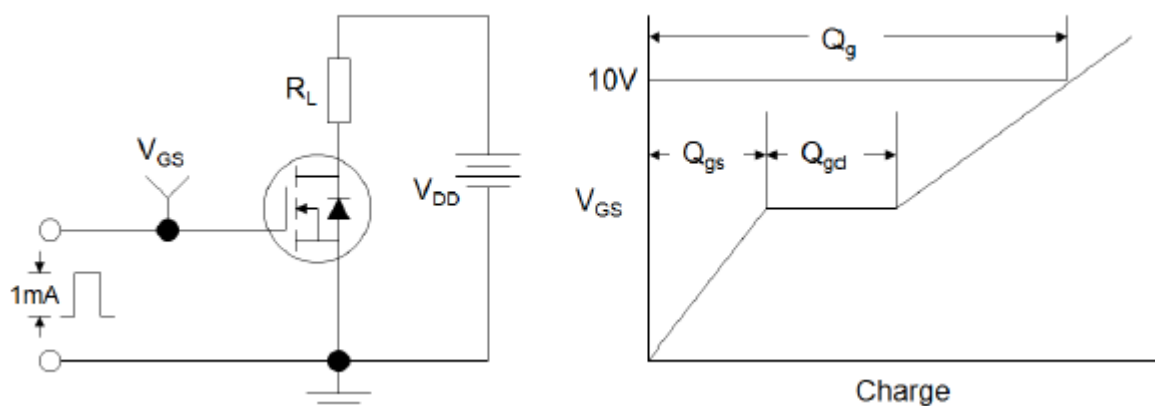

Figure 1: Gate Charge Test Circuit & Waveform

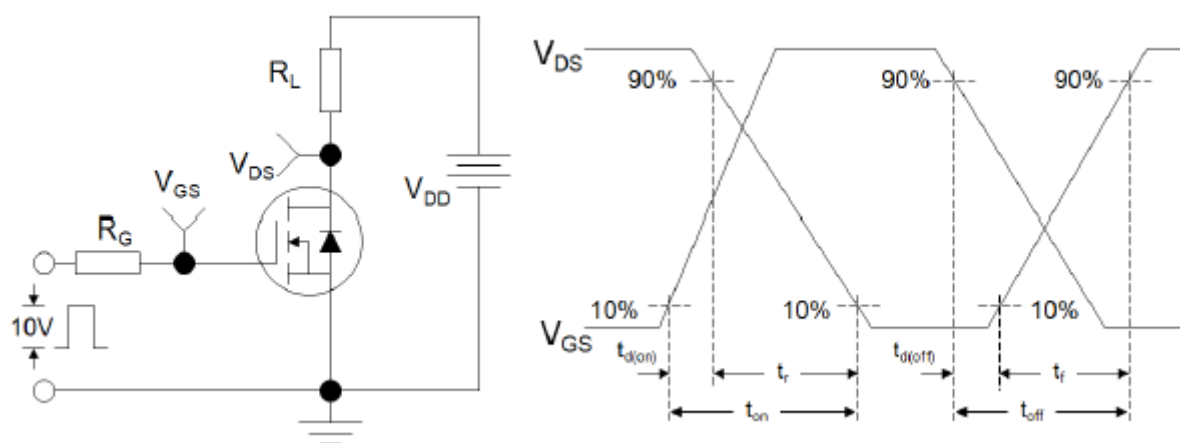

Figure 2: Resistive Switching Test Circuit & Waveforms

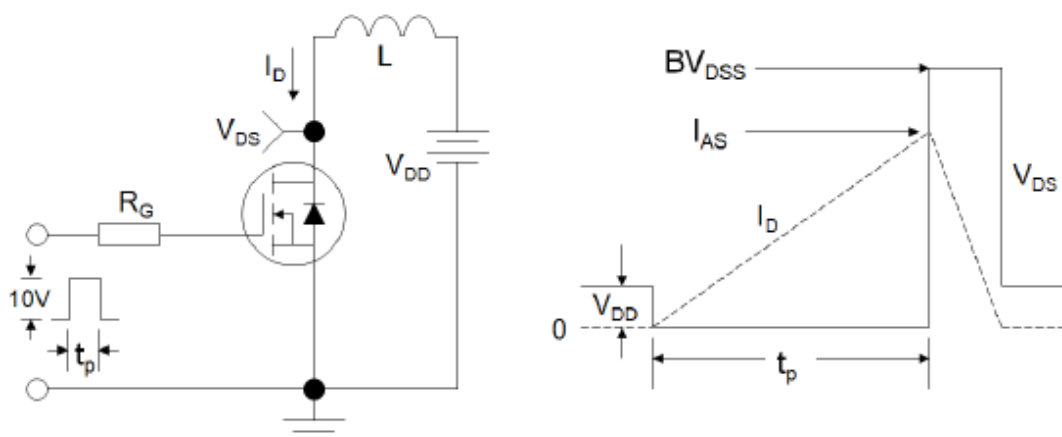

Figure 3: Unclamped Inductive Switching Test Circuit & Waveforms

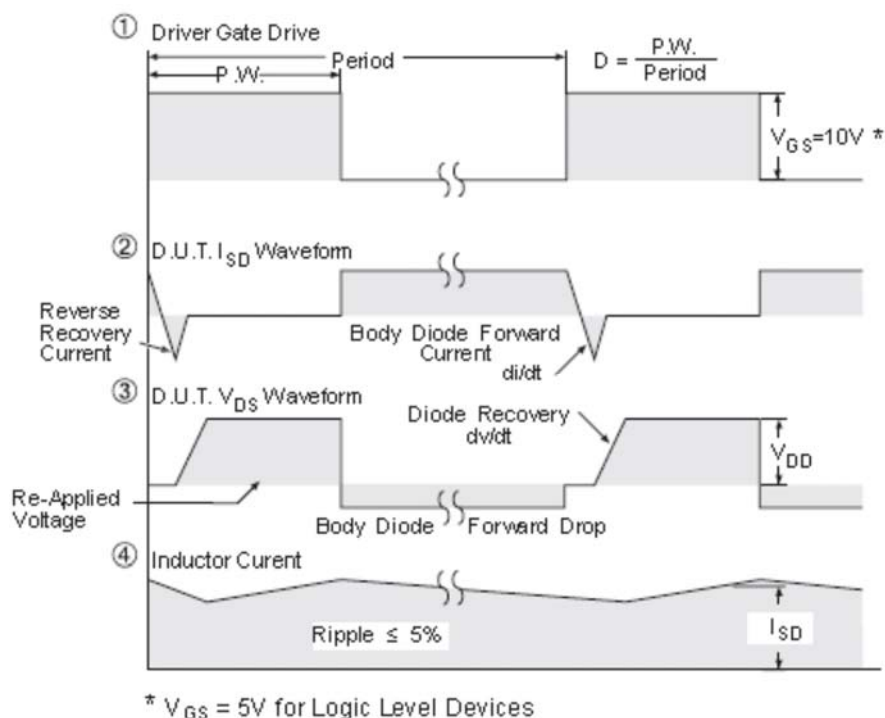
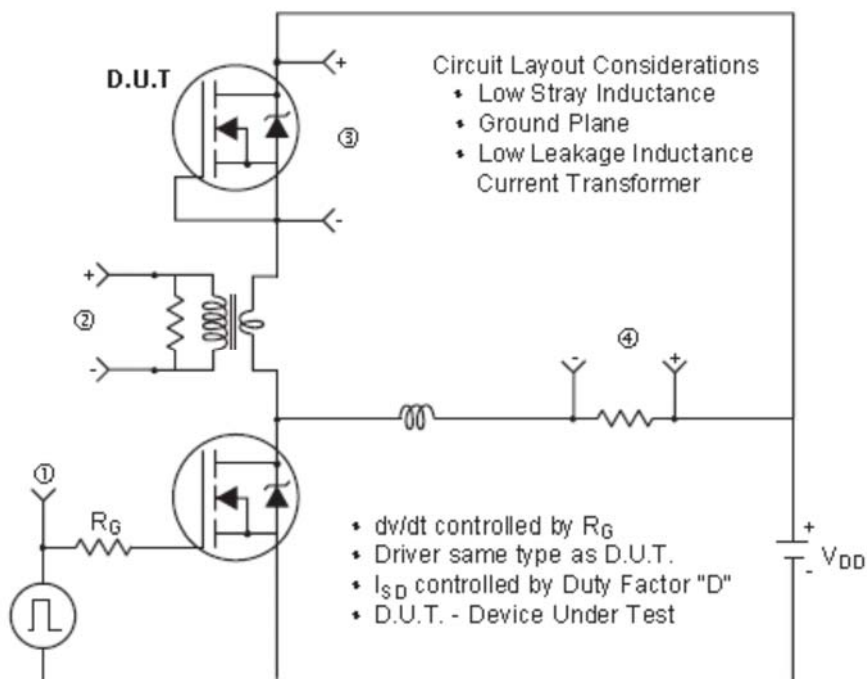
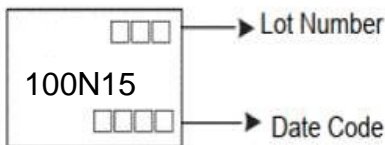

Figure 4: Peak Diode Recovery dv/dt Test Circuit & Waveforms (For N-channel)

Ordering and Marking Information

Ordering Device No.	Marking	Package	Packing	Quantity
JMD100N15KQ-R	100N15	TO252	Tape&Reel	2500

PACKAGE	MARKING
TO252	

Package Mechanical Data

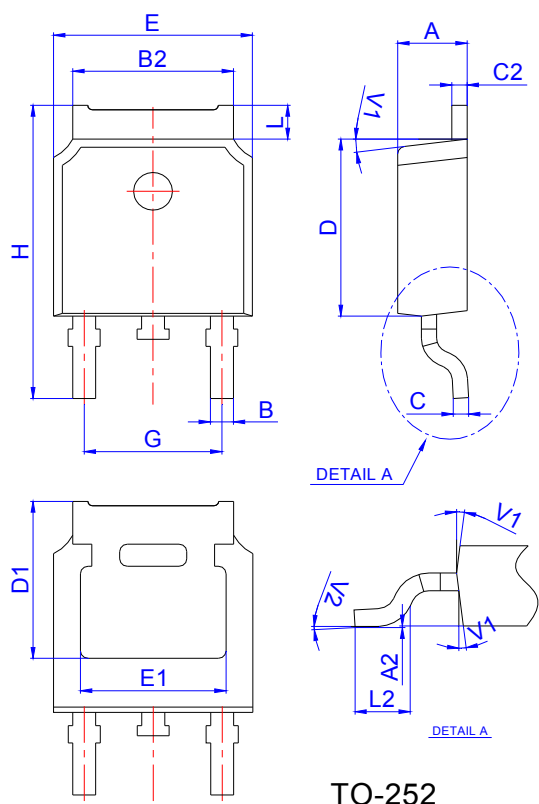

Ref.	Dimensions					
	Millimeters			Inches		
	Min.	Typ.	Max.	Min.	Typ.	Max.
A	2.10		2.50	0.083		0.098
A2	0		0.10	0		0.004
B	0.66		0.86	0.026		0.034
B2	5.18		5.48	0.202		0.216
C	0.40		0.60	0.016		0.024
C2	0.44		0.58	0.017		0.023
D	5.90		6.30	0.232		0.248
D1	5.30REF			0.209REF		
E	6.40		6.80	0.252		0.268
E1	4.63			0.182		
G	4.47		4.67	0.176		0.184
H	9.50		10.70	0.374		0.421
L	1.09		1.21	0.043		0.048
L2	1.35		1.65	0.053		0.065
V1		7°			7°	
V2	0°		6°	0°		6°

Reel Specification-TO-252

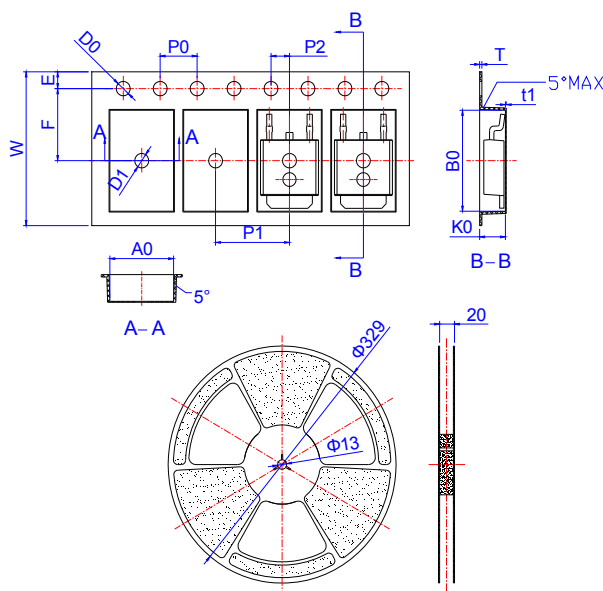

Ref.	Dimensions					
	Millimeters			Inches		
	Min.	Typ.	Max.	Min.	Typ.	Max.
W	15.90	16.00	16.10	0.626	0.630	0.634
E	1.65	1.75	1.85	0.065	0.069	0.073
F	7.40	7.50	7.60	0.291	0.295	0.299
D0	1.40	1.50	1.60	0.055	0.059	0.063
D1	1.40	1.50	1.60	0.055	0.059	0.063
P0	3.90	4.00	4.10	0.154	0.157	0.161
P1	7.90	8.00	8.10	0.311	0.315	0.319
P2	1.90	2.00	2.10	0.075	0.079	0.083
A0	6.85	6.90	7.00	0.270	0.271	0.276
B0	10.45	10.50	10.60	0.411	0.413	0.417
K0	2.68	2.78	2.88	0.105	0.109	0.113
T	0.24		0.27	0.009		0.011
t1	0.10			0.004		
10P0	39.80	40.00	40.20	1.567	1.575	1.583

OUTLINE	REEL (PCS)	PER CARTON (PCS)	TAPE & REEL
TAPING	2,500	25,000	13inch

Disclaimer

The content specified herein is for the purpose of introducing JMW's products (hereinafter "Products"). The information given in this document shall in no event be regarded as a guarantee of conditions or characteristics. Examples of application circuits, circuit constants and any other information contained herein illustrate the standard usage and operations of the Products. The peripheral conditions must be taken into account when designing circuits for mass production.

JMW does not assume any liability for infringement of patents, copyrights, or other intellectual property rights of third parties by or arising from the use of the Products or technical information described in this document.

The Products are not designed or manufactured to be used with any equipment, device or system which requires an extremely high level of reliability the failure or malfunction of which may result in a direct threat to human life or create a risk of human injury (such as a medical instrument, transportation equipment, aerospace machinery, nuclear-reactor controller, fuel-controller or other safety device). JMW shall bear no responsibility in any way for use of any of the Products for the above special purposes.

Although JMW endeavors to improve the quality and reliability of its products, semiconductor products have specific characteristics such as the occurrence of failure at a certain rate and malfunctions under certain use conditions. Please be sure to implement safety measures to guard them against the possibility of physical injury, and injury or damage caused by fire in the event of the failure of a JMW product.

The content specified herein is subject to change for improvement without notice. When using a JMW product, be sure to obtain the latest specifications.